



Briggs & Stratton

World Formula

Tech Manual



First Issued: May 22, 2007
Updated: FEB, 2010
Rusty Barnard QMA Tech

© 2009 Quarter Midgets of America, Inc.

QMA Tech Director

Section 1

General Rules

1. Only stock Briggs & Stratton World Formula Model # 124435-8101-8106-01 will be used in this class except as provided in this Tech Manual. All parts will be stock unaltered Briggs & Stratton World Formula parts specifically made for this engine by Briggs & Stratton.
2. Direct Drive: Clutches are not allowed.
3. Unless otherwise specifically required or allowed by this Tech Manual no machining or alterations of any kind will be allowed to the World Formula engine or replacement parts to be used in any World Formula engine for QMA unless specifically stated in these rules. **ALL PARTS ARE SUBJECT TO COMPARISON WITH A KNOWN STOCK PART.**
4. Modifications or machining of any parts in order to bring them to stated minimum/maximum specs, (or for any reason). "Blueprinting" is not legal.
5. Fuel: Gasoline only, no additives. Tech procedure is per QMA Rule Book Article 9.
6. **ALL PERTINANT PENALTIES WILL APPLY.**

Section 2

Required Modifications

1. **Gearbox:** Any gearbox is approved. Crankshaft may be altered only on external output shaft by adding a gear to drive the gearbox. All other modifications to crankshaft are illegal.
2. **Electric Starter:** Electric starter must be removed and blower housing openings must be covered with a fabricated metal cover. You should not be able to see **any** of the flywheel.
3. **Recoil Starter:** Recoil starter must be removed. Starter cup must be cut down or replaced with a flat washer, Briggs Part number 691736 for flat washer.
4. **Exhaust:** Must use exhaust port extension in port. Minimum of a 0.520 length measured from the bottom of the exhaust flange to the end of the pipe using a depth mic. Any style pipe and max of four, (4) B & S mufflers only.
5. **Oil Breather:** Oil breather must vent to catch can under the tail cone within the engine compartment.
6. **Carburetor Overflow:** Carburetor overflow may be vented to the ground.
7. **Impulse Fitting on Intake Manifold:** Impulse fitting on intake manifold must be filed if impulse type fuel pump is not used.
8. Scattered shield required.

Section 3

Allowable Modifications

1. **Crankshaft Seal:** No tech on the crankshaft seal on gearbox side.
2. **Flywheel Cup:** Flywheel cup may be cut or replaced with a washer, Briggs Part number 691736.
3. **Fuel Pump:** Fuel pump, B & S part number 557033 may be used. If used, fuel pump must be pulsed from the intake manifold pulse fitting only.
4. **Black Plastic Control Cover:** Black control cover B & S part number 557048 and bracket # 555618 including ON/OFF switch may be removed. May be replaced with a metal cover plate (Briggs Plate Part number 555699) and bolted to top of engine. Blower housing openings must be covered with fabricated metal cover.
5. **Rocker Cover:** Rocker cover B & S part number 555528 may be modified for installation of oil breather line fitting. (It is allowable to have secondary drilling of holes in the breather valve area of the valve cover.)

6. The installation of the Briggs Breather By-pass system, part number 555688, per included ms-3742 sheet. Must be tee into catch can.
7. **Plastic Flywheel Ring Gear:** Plastic flywheel ring gear may be removed. No other alterations including the addition or subtraction of metal to the flywheel are allowed.
8. Heat Dispenser, Briggs part number 555690, may be installed per included ms-3758
9. Can use Briggs PVL system: Part Number 557127.
10. Manifold adaptor: Part Number 55769.
11. Head Gasket Fire Ring: Part Number 55698

12. Flywheel may be lapped stock key must be used.

Section 4 Tech Procedure

1. General

- a. Heli-coiled threads for shrouds, (all), valve cover, oil drain, oil fill holes, blower housing, and exhaust pipe attach studs on the head and lower brackets.
- b. Blocking airflow: No device may be used that will, or appears that it may impede airflow into the engine cooling system. This may require that the engine be run at a speed above idle by the tech personnel at the scale, after the car has qualified or raced.

2. Carburetor

Remove Carburetor

- a. Stock Walbro PZ26 carburetor ending in calibration number .A63 Carb only. No alterations allowed. Slide must remain unaltered. Stock needle marked "CDB" is required.
- b. Needle Jet C-clip must be properly installed but may be installed at any of the 5 factory settings on the needle jet.
- c. Throttle cable cap on the top of the carburetor must be used and properly installed. Cap must be tight.
- d. Choke: Unaltered, but may be fastened open with a spring, rubber band, or zip tie.
OR Remove choke and plug with silicone.
- e. Idle Jets any size allowed.
- f. Main Jets any size allowed.
- g. Venturi Measurement:
Vertical: 25.00mm +/- .15mm
Horizontal: 18.50mm +/- .25mm, 00mm
- h. Carburetor Adapter: Carb adapter B & S part number 557050 or updated B & S part number must be used in stock configuration.
- i. Air Filter: B & S part number 557087 is the only air filter allowed but is not required to be used.
- j. Carburetor Overflow: May be vented to the ground.
- k. O-Ring part number B & S part number 557007 is required and must be unaltered.

3. Engine Cooling Shrouds/Blower Housing

- a. All pieces of the stock engine cooling shroud/blower housing must be stock and properly installed.
- b. Starter cup may be cut down.

Remove blower housing

Remove valve cover



Check:

1. Max. valve lift will be checked from the top of the valve spring retainer. Valves must be adjusted to zero clearance.
2. Valve Lift: First camshaft check will be taken at the valve spring retainers. With the lash set at zero, the movement of the valve spring retainers may not exceed the following:
Intake and Exhaust: .3097 inches max.
3. Install Degree wheel, using positive stop method.
Check ignition timing. With the right edge of the magnet, (not the magnet holder), aligned with the right edge of the notch of the right leg of the coil, the engine must be from 23° BTDC to 27° BTDC You must use stock key way and unaltered flywheel stock Briggs and Stratton only allowed.
4. Tech camshaft at pushrods. Push gently down on dial indicator stem to ensure that there is no lash when push rods are going down.

4. Cylinder Head & Head Gasket

Remove cylinder head.

Head Gasket:

- a. Stock, unaltered B & S part number 555698 fire ring gasket allowed.
- b. Minimum gasket thickness between head bold holes .041 inches.
Measurements are to be made with dial caliper from inside of fire ring.

Head:

- a. Cylinder head, 557101 or 557133 (includes the heat dispenser installed) must be stock, unaltered and be in " as cast" and in factory-machined condition. No additions to or subtractions from any part of head with the exception of Heat Dispenser, Briggs Part number 555690 may be installed per included ms-3758.
- b. Exhaust pipe attachment stud may be heli-coiled.
- c. No alterations of any kind may be made to the intake or exhaust ports.
- d. Combustion Chamber: 19.6 cc to 20.6 cc
- e. Intake Port:
Maximum diagonal measurement = 1.101 inches
Maximum vertical measurement = 1.044 inches
- f. Exhaust Port AS CAST:

Maximum ID of shoulder in bottom of exhaust port = .854 inches.

- g. Valve Seats, Intake and Exhaust: Must remain factory spec. with one 45° angle only. Multi angle valve seats are not permitted.
- h. Intake valve seat diameter inside = .965 to .972 inches.
- i. Exhaust valve seat diameter inside = .844 to .850 inches.



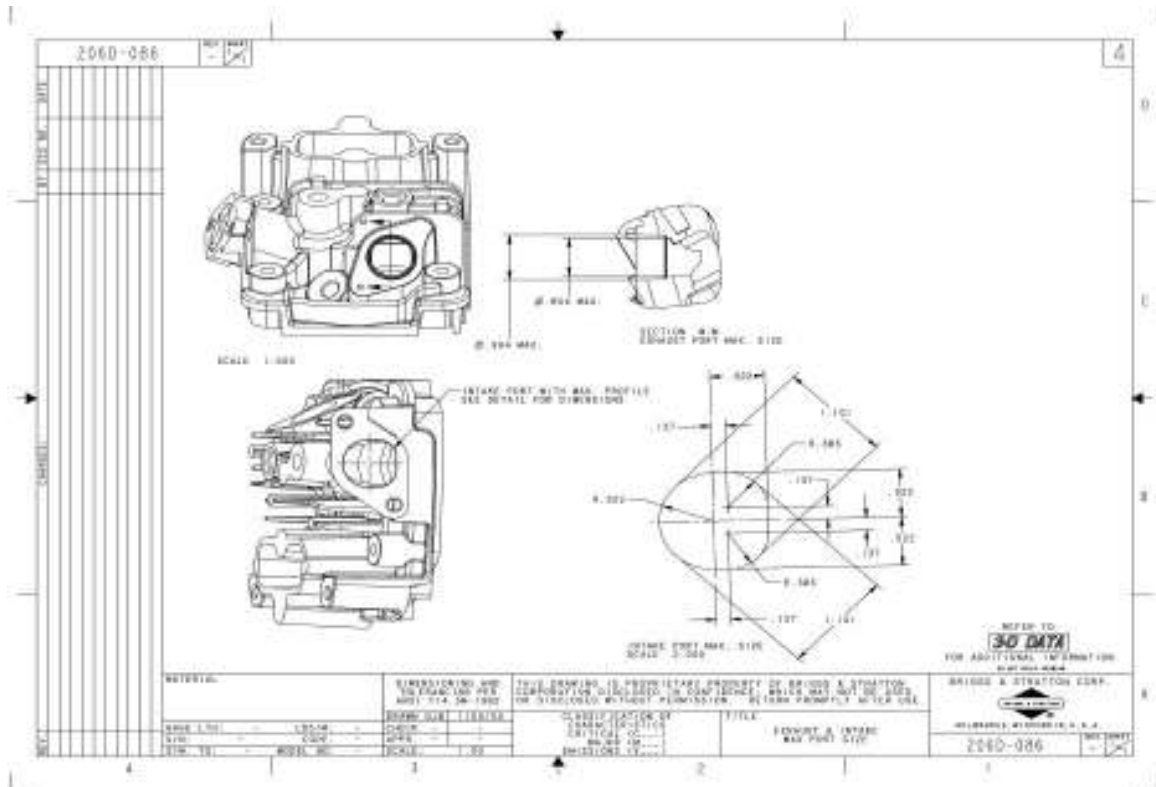

Remove Valves

Inspect retainers for alterations that would increase valve spring pressure. Both intake and exhaust must have stock B & S valve keepers.

5. Valves

- a. Check valves for dimensions and weight. Stock and unaltered B & S part #557018 (exhaust) and #557017 (intake). Valve surface must be unaltered factory ground and have one 45° sealing surface only. There will be no other angles ground on any part of the valve.
- b. Valve Guides: Replacement of valve guides with B & S factory part # 555645 only is allowed.
- c. Intake Valve:

Minimum Weight of Valve	29.26 grams min.
Diameter of Valve Stem	.246 to .247
Diameter of Valve Head	1.055 to 1.065 inches
Diameter of Valve Seat	.965 to .972 inches ID
- d. Exhaust Valve:

Minimum Weight of Valve	28.62 grams min.
Diameter of Valve Stem	.246 to .247
Diameter of Valve Head	.935 to .945 inches

Diameter of Valve Seat .844 to .850 inches ID

6. Valve Springs

- a. Valve Springs will be dual coil stock, unaltered B & S part # 557024.
- b. Inner Spring
Inner Wire Diameter .066 to .068 inches.
- c. Outer Spring
Outer Wire Diameter .112 to .114 inches

7. Rocker Arms and Rocker Arm Studs

- a. Rocker arms will be stock B & S part # 557015 and will not be altered in any way.
- b. Rocker studs will be stock, unaltered B & S part # 555549 AND in stock location.
- c. Rocker Ball must be stock.
Diameter .590 inch min. to .610 inch max.
- d. Rocker arm mounting positions may not be altered in any manner. No Heli-coiling of mounting holes. No bending of studs. Rocker arm stud plate must be bolted to the head with one stock B & S gasket only – no alterations.

8. Push Rods

- a. Push rods will be stock, unaltered B & S part # 555531.

9. Engine Block

- a. Engine block must be in “ as cast - stock factory machined condition with no alterations. There must be no addition or subtractions of metal or any substance to the inside or outside of the cylinder block.
- b. No machining of deck surface is permitted.
- c. Cylinder block deck will not be resurfaced by any means. There will be no polishing, sand blasting, or glass beading to any interior surface.
- d. Cylinder bore will not be bored oversize.
- e. Cylinder bore will not be re-sleeved.
- f. Cylinder bore position will not be moved or tipped in any manner.
- g. Cylinder Bore Dimension: 2.688 inches +/- .0005 max. Taken at top or bottom of bore.
- h. Check Stroke: 2.193. Push piston down to take up rod play.

Cam Shaft Profile Limits

- a. First camshaft check will be taken at the valve spring retainers. With the lash set at zero, (0), the movement of the valve spring retainer may not exceed .3085 inches. Camshaft must be supplied with compression relief.
- b. Tech camshaft at pushrods. Push gently down on dial indicator stem to ensure that there is no lash when push rods are going down.

<u>INTAKE LOBE</u>	<u>LIFT</u>	<u>EXHAUST LOBE</u>
<u>13 TO 17</u>	<u>BTDC .050</u>	<u>232 TO 236 BTDC</u>
<u>0 TO 5</u>	<u>BTDC .100</u>	<u>215 TO 219 BTDC</u>
<u>13 TO 17</u>	<u>ATDC .150</u>	<u>201 TO 205 BTDC</u>
<u>30 TO 34</u>	<u>ATDC .200</u>	<u>185 TO 189 BTDC</u>
<u>50 TO 54</u>	<u>ATDC .250</u>	<u>165 TO 168 BTDC</u>
<u>64 TO 67</u>	<u>ATDC .275</u>	<u>150 TO 154 BTDC</u>
<u>307 MAX (107 TO 111 CL.)</u>		<u>307 MAX (108 TO 111 CL.)</u>
<u>148 TO 152</u>	<u>ATDC .275</u>	<u>68 TO 72 BTDC</u>
<u>162 TO 165</u>	<u>ATDC .250</u>	<u>53 TO 57 BTDC</u>
<u>182 TO 186</u>	<u>ATDC .200</u>	<u>32 TO 36 BTDC</u>
<u>198 TO 203</u>	<u>ATDC .150</u>	<u>16 TO 20 BTDC</u>
<u>213 TO 217</u>	<u>ATDC .100</u>	<u>1 TO 5 BTDC</u>
<u>228 TO 232</u>	<u>ATDC .050</u>	<u>12 TO 16 ATDC</u>

10. Flywheel

No modifications allowed to flywheel.

- a. Stock B & S part # 557126 only. No machining, glass beading, sand blasting, painting or coating of flywheel is allowed.
- b. Flywheels with broken fins must be replaced.
- c. Plastic starter ring gear between flywheel and engine may be removed.
- d. Stock, unaltered flywheel key is required. No offset keyways allowed.
- e. Can use any flat washer under flywheel nut. You **can** use factory cup.

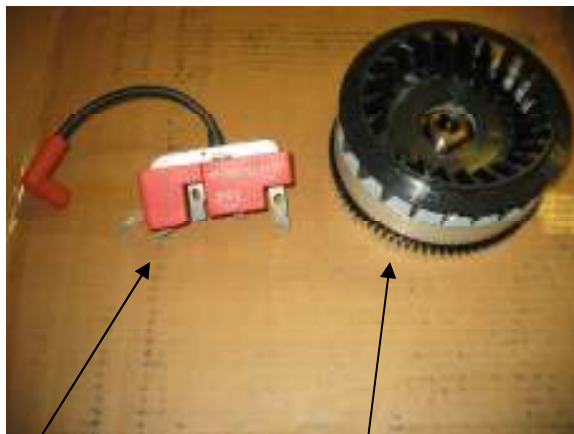

Coil Part #557125

Flywheel Part #557126



Red Coil Only - No Other Allowed

11. Ignition System

- a. Unaltered B & S stock Ignition part # 557125 is mandatory. Only "RED" Coil allowed. Ignition Coil or its position, other than air gap may not be altered in any way. Coil mounting bolts must be stock and cannot be altered in any way to advance or retard timing. Attachment bolts and/or boltholes may **not** be altered.
- b. Spark plug: Any automotive type with 10mm thread only, unaltered with stock washer allowed. Indexing washers is not allowed. Standard spark plug is Champion RG519HC.
- c. Magneto air gap is non-tech.
- d. Timing:
 - Normal = 29° BTDC,
 - Min. = 27° BTDC
 - Max. = 31° BTDC
- e. (Space reserved for future use)

12. Gear Box

- a. Gearbox is not considered part of the engine and in non-tech; therefore any gear reduction box may be used.



Part # 555721 complete gear box

13. Crankcase Cover

Remove crankcase cover

- a. Cover must be in stock, unaltered, " as cast in factory" condition. No alterations or subtractions of metal or any other substance to crankcase cover.
- b. Crankcase cover gasket must be stock B & S part # 555525. One gasket max. may be installed.

14. Piston

Remove rod and piston.

- a. Stock and unaltered B & S " kidney bean" piston - part # 557001 only.
- b. Minimum from top of piston to top of wrist pin on circlip side is .685 to .686 in.
- c. Minimum piston length is 1.768 in.
- d. Oversized pistons are not allowed.

- e. Weight: Complete combination includes piston, rings, rod, clip, cap, and bolts:
300 grams – min. OR 10.6 oz min
NOTE: Torque head assembly- average 357 grams
Hex head assembly- average 360 grams

15. Rings

- a. Must be stock; unaltered B & S rings part # 555664 only.
This set contains file to fit top ring.
- b. No decreasing of ring tension by heating, machining or any other means.
- c. Three rings mandatory
 1. Top compression ring must have chamfer or O toward top of piston.
 2. Second scraper ring must be installed with inside chamfer down and O toward the top of piston.
 3. Oil ring must be installed as from factory.
- d. Minimum width of top two rings is .095 inches.
- e. Thickness of top two rings is .059 to .064 inches. (each ring)
- f. Minimum width of oil ring is .065 inches. Ring groove must be present.
- g. Thickness of oil ring is .098 to .102 inches.

16. Wrist Pin

- a. Must be stock, unaltered B & S part # 555520 wrist pin and lock part # 555521
- b. Wrist Pin:
 - Maximum I.D. = .414" +/-
 - Max. O.D. = .626"
 - Minimum length – 1.901"

17. Connecting Rod

- a. Must be stock, unaltered B & S part # 557005 or 555117 (hex head bolts).
- b. Rod length, measurement from bottom of wrist pin hole of top of crank journal hole is 2.419 inches minimum to 2.429 inches maximum.
- c. Diameter of big end = 27.9476 mm - 1.003" ref
- d. Diameter of small end – 15.89405 mm - 0.625" ref

18. Crankshaft

- a. Stock B & S part # 555620 or 557135 crankshaft must remain unaltered except the following:
 - Crankshaft may be altered only on external output shaft and only by adding a gear to drive the gearbox. All other modifications to the crankshaft are illegal.
- b. Crankshaft journal diameter = 1.094 inches to 1.100 inches.
- c. Stock, unaltered B & S part # 555573 bearings required.
- d. B & S part 555054 key-flywheel.
- e. Shim, (s), Briggs Part number 55619, if used must be installed as from factory.
- f. Stock, unaltered part # 555574 timing gear installed in stock location on crankshaft only.
- g. No offset keyways allowed on cam gear for crankshaft.



Splined Crankshaft Part #555722

19. Camshaft

- a. Stock, unaltered B & S part # 557041 camshaft.
- b. There will be no additions or subtractions from any part of the camshaft.
- c. Compression release will remain intact and unaltered.
- d. Lobe center angle will not be altered by any means.
- e. Lobe profile will not be altered in any way.

20. Tappets

- a. Stock, unaltered B & S part # 557038 tappets only.
- b. Tappet diameter = .964 to .984 min. max.

Torque Specifications:

Non-Tech, recommended by B & S

Flywheel Nut	55-75 ft. lbs. (74.5-101 Nm)
Cylinder Head	180-22- in. lbs. (20-25 Nm)
Connecting Rod	120-140 in. lbs. (13.5-15.8 Nm)
Crankcase Cover	120-140 in. lbs. (13.5-15.8 Nm)
Cylinder Head Plate	70-90 in. lbs. (8-10 Nm)
Rocker Arm Stud	70-11- in. lbs. (8-12.5 Nm)
Valve Cover	30-60 in. lbs. (3.5 -7 Nm)
Spark Plug	95 - 145 in. lbs. (11-16 Nm)
Intake and Exhaust	Measured at TDC .005 -.007 in. (.127 - .178mm)
Flywheel Holder Tool	Part # 19372
Valve Lash	Cold